

The Sovereign ULTIMA from Robert Sorby is the most technically advanced hollowing system in the world. It has been specifically designed to allow the user to produce hollow forms quickly and efficiently. When used in conjunction with the Sovereign handle system it is the Ultimate hollowing tool for all woodturners.

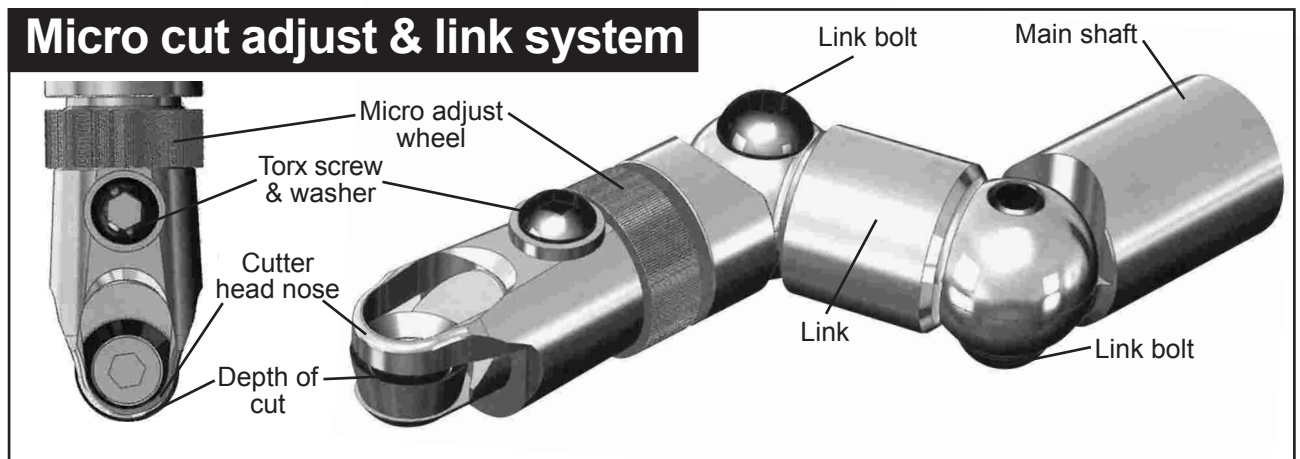

The depth of cut can be altered depending on the type of wood being used, whether it is wet or dry and the speed of the lathe. The depth is determined by the amount that the cutter is protruding from the nose of the cutter head. This distance is factory set slightly wider than the thickness of paper but less than that of a credit card. The depth of cut is the thickness of waste material that will be removed during each cut.

To adjust this, slacken the Torx screw in the top of the cut adjustment cap and turn the micro adjust wheel as required. Looking from above, turn it to the right will decrease and to the left will increase the depth of cut. The head position is factory set at its most stable position with the cutter inline with the centre of the shaft. The head and link can be adjusted to any desired position allowing for deeper under shoulder cutting.

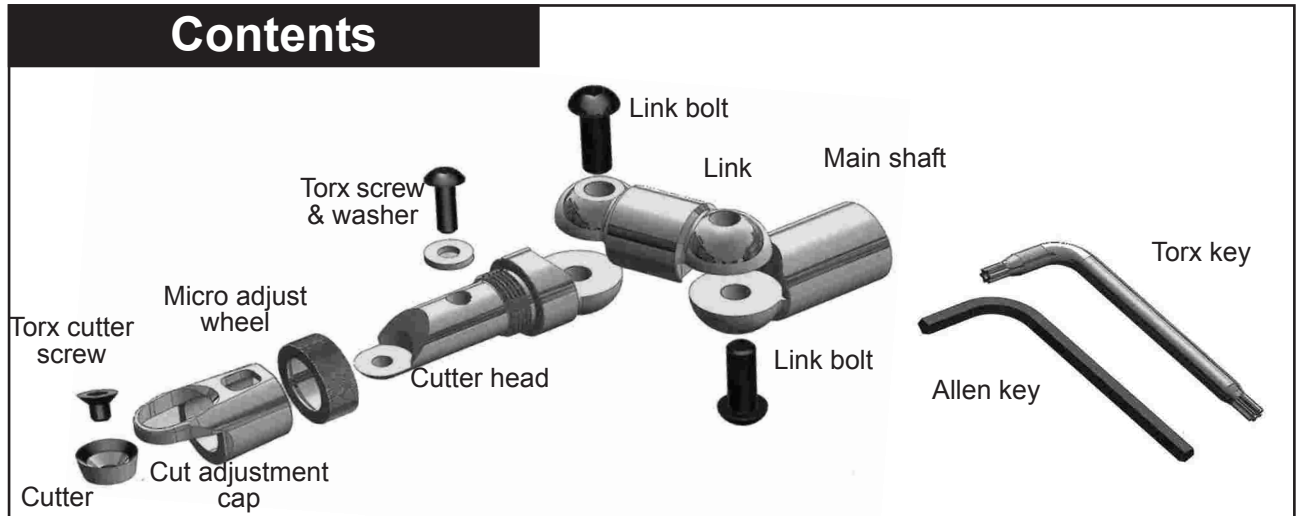
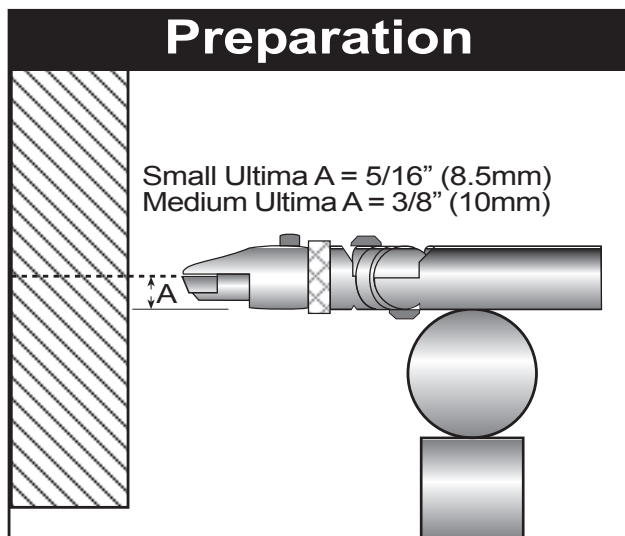

Set the tool rest so that the edge of the cutter is on centre using the dimensions as shown above as a guide.

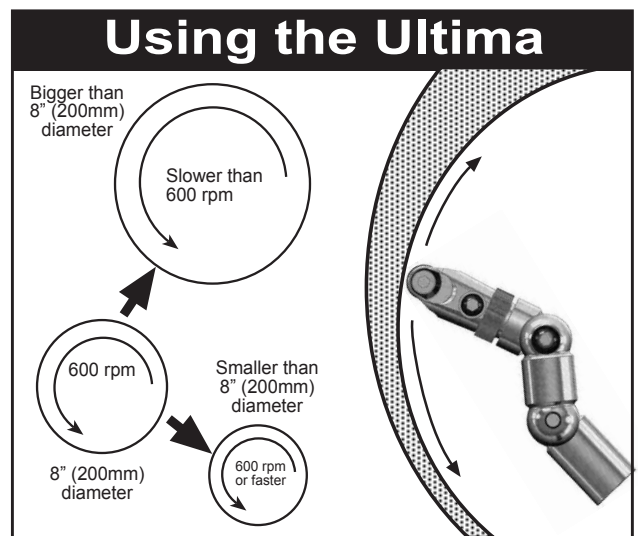

The Ultima is designed to cut with little effort. Use with a smooth sweeping action to give a comfortable and controlled cut.

The lathe should always be set to a SAFE and practical speed. The information above is only a guide and individual factors such as size of wood, capabilities of the lathe and personal experience should be considered.

Hollowing

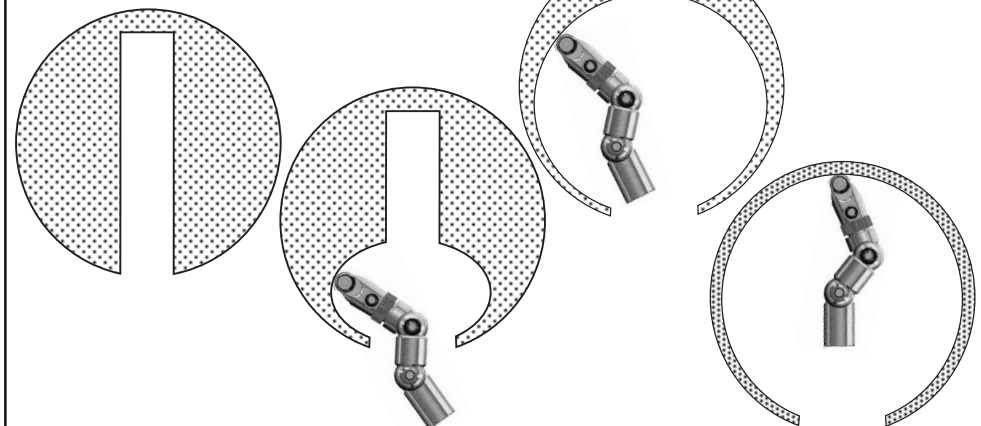

Drill a central bore to remove the slow moving centre section and allow waste material from the hollowing tool to clear from the cutting area. After creating the centre bore, begin hollowing the first section. Finish the wall thickness as

required before cutting deeper into the piece. Change the position of the head and link as required. Finish each section before moving down to the next portion of the piece. Use light sweeping cuts to achieve an even wall thickness.

Cutter setting

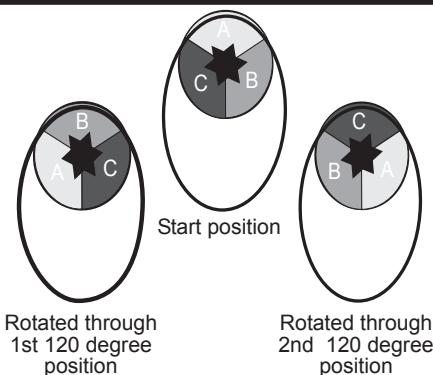

When the cutter becomes less sharp it can be rotated through 120 degrees to reveal a new sharp edge. This can be done twice before sharpening is required. Always clear dust from Allen & Torx key sockets.

Cutter and cap care

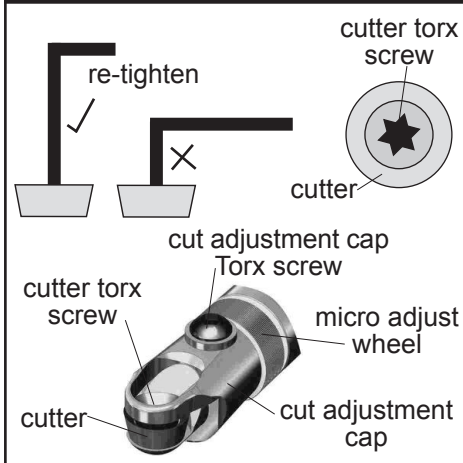

Tighten the cutter torx screw using only the key as shown above. To remove the cut adjustment cap first remove the cutter and slide the cap away.

To replace, slide the cap up to the micro-adjust wheel and replace the cutter.

Honing & sharpening

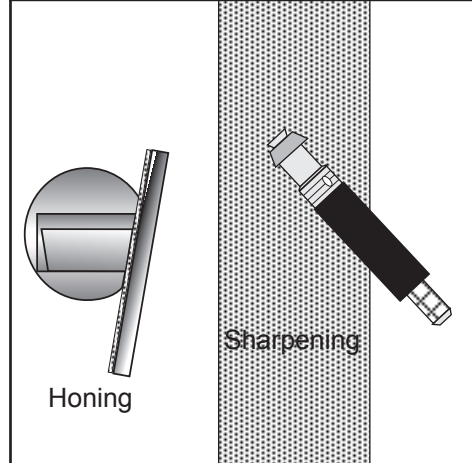

The cutter can be honed whilst on the tool using a diamond or honing stone. Gently sweep around the face keeping the abrasive flat on the bevel.

The optional cutter sharpening jig is simple to use and helps to produce a very sharp edge when used with a fine abrasive belt or wheel.

Finishing

Optional Finishing Cutter Head
Ref: SOV-ULTFCHS & SOV-ULTFCHM

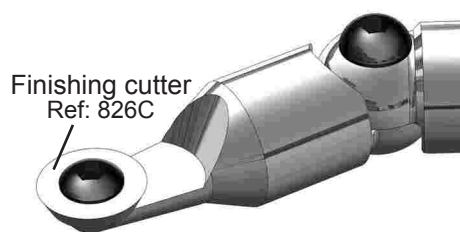

This head can be easily fitted to the Ultima and the small round scraper cutter will provide a smooth surface finish to all hollowed projects. Additional cutters can be added, see list below.

Optional extras

Cutter sharpening jig
Ref:SOV-ULTCSJ

The versatile cutter sharpening jig is designed to allow a new sharp edge to be achieved on the hollowing cutter of the Ultima simply and easily. It can also be used to sharpen any round cutters including the scraper cutters fitted to the finishing cutter head and the additional full-round cutter.

Optional finishing cutters

A range of additional scraper cutters can be added to the finishing cutter head for use on specific projects. The cutters include the mushroom cutter (Ref:804C09), small tear-drop cutter (Ref:RS222) and the full-round cutter (Ref:RS230C).

Additional link

Ref: SOV-ULTS & SOV-ULTM

The additional link allows more variety of adjustment of the cutter head for advanced undercutting to be achieved.

Optional blades for the Sovereign system

The multi-functional Robert Sorby Sovereign system allows for a large range of blades to be fitted to your Sovereign handle.

1/4", 3/8", 1/2" & 3/4" Bowl gouges fingernail & standard profile (Ref: 842 & 842F)

3/8" & 1/2" Spindle gouges fingernail & standard profile (Ref: 840 & 840F)

3/8" & 1/2" Long & strong spindle gouges (Ref: 841)

1/2" & 3/4" Extra long bowl gouges (Ref: 8427)

Midi multi-tipped hollowing tool (Ref: SOV-RS100)

Midi Hollowmaster (Ref: SOV-RS130)

Multi-tipped hollowing tool (Ref: SOV-RS200)

Hollowmaster (Ref: SOV-RS230)

Extra long multi-tipped hollowing tool (Ref: SOV-RS300)

Extra long hollowmaster (Ref: SOV-RS340)

Robert Sorby

Athol Road, Sheffield, England, S8 0PA

+44 (0) 1142250700

www.robert-sorby.co.uk

sales@robert-sorby.co.uk