

RECORD POWER

ESTABLISHED 1909®

Original Instructions

80003 Coronet Cobra Bandsaw Scroll Guide System

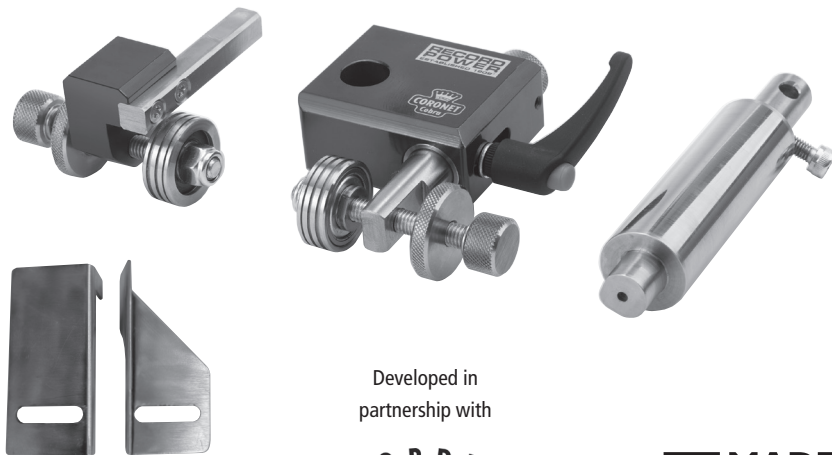

Developed in
partnership with

BORDET

FRANCE

Est. 1965



TRAVAIL DU BOIS
OUTILLAGE ET MATERIEL

MADE IN
BRITAIN®

MADE IN
SHEFFIELD

Version 3.1
May 2023



To register this product please visit
www.recordpower.info

It is important to register your product as soon as possible in order to receive efficient after sales support and be entitled to the full **5 year guarantee**. Your statutory rights are not affected. Please see back cover for contact details.



Always wear safety glasses
when using woodworking
equipment.



Always read the instructions
provided before using
woodworking equipment.

Important

For your safety read instructions carefully before
assembling or using this product.

Save this manual for future reference.

Contents

- 1** Explanation of Symbols
- 2** Record Power Guarantee
- 3** General Health & Safety Guidance
- 4** Additional Health & Safety Guidance for Bandsaws
- 5** Specifications
- 6** Contents of the Package
- 7** Assembly
- 8** Operation
- 9** Maintenance
- 10** Dust Extraction
- 11** Parts Lists & Diagrams

1. Explanation of Symbols

THE SYMBOLS AND THEIR MEANINGS SHOWN BELOW MAY BE USED THROUGHOUT THIS MANUAL. PLEASE ENSURE THAT YOU TAKE THE APPROPRIATE ACTION WHEREVER THE WARNINGS ARE USED.

Mandatory Instructions



Read and fully understand the instruction manual before attempting to use the product



Indicates an instruction that requires particular attention



Wear protective eyewear



Use respiratory protective equipment



Use hearing protection



Use suitable protective footwear



Use protective work gloves

Warning



Indicates a risk of severe personal injury or damage to the machine



Indicates a risk of severe personal injury from electrical shock



Risk of personal injury from lifting of heavy items



Indicates a risk of severe personal injury from airborne objects



Risk of fire

2. Record Power Guarantee

“**Products**” means the Products sold by Record Power subject to these terms and conditions;

“**Record Power**” is Record Power Limited, whose company registration number is 4804158 and registered office address is Centenary House, 11 Midland Way, Barlborough Links, Chesterfield, Derbyshire, S43 4XA and sells through a network of Authorised Dealers;

“**Authorised Distributor**” is the nominated importer for your region who will generally sell through a network of Authorised Dealers. Details of Authorised Distributors for specific countries can be found in the Product manual or at www.recordpower.info;

“**Authorised Dealer**” is a retailer or business authorised to sell Record Power Products to end users.

1 Guarantee

- 1.1 Record Power guarantees that for a period of 5 years from the date of purchase the components of qualifying Products (see clauses 1.2.1 to 1.2.9) will be free from defects caused by faulty construction or manufacture.
- 1.2 During this period Record Power, its Authorised Distributor or Authorised Dealer will repair or replace free of charge any parts which are proved to be faulty in accordance with paragraphs 1.1 above provided that:
 - 1.2.1 you follow the claims procedure set out in clause 2 below;
 - 1.2.2 Record Power, our Authorised Distributor or Authorised Dealer are given a reasonable opportunity after receiving notice of the claim to examine the Product;
 - 1.2.3 if asked to do so by Record Power, its Authorised Distributor or Authorised Dealer, you return the Product, at your own cost, to Record Power’s premises or other approved premises such as those of the Authorised Distributor or supplying Authorised Dealer, for the examination to take place;
 - 1.2.4 the fault in question is not caused by industrial use, accidental damage, fair wear and tear, wilful damage, neglect, incorrect electrical connection, abnormal working conditions, failure to follow our instructions, misuse, or alteration or repair of the Product without our approval;
 - 1.2.5 the Product has been used in a domestic environment only;
 - 1.2.6 the fault does not relate to consumable Products such as blades, bearings, drive belts or other wearing parts which can reasonably be expected

to wear at different rates depending on usage (for full details contact Record Power or your local Authorised Distributor);

- 1.2.7 the Product has not been used for hire purposes, by you or by a previous owner;
- 1.2.8 the Product has been purchased by you as the guarantee is not transferable from a private sale.
- 1.2.9 where the Product has been purchased from a retailer, the 5 year guarantee is transferable and begins on the date of the first purchase of the Product and in the event of a claim under this guarantee proof of the original purchase date will be required to validate the warranty period.

2 Claims Procedure

- 2.1 In the first instance please contact the Authorised Dealer who supplied the Product to you. In our experience many initial problems with machines that are thought to be due to faulty parts are actually solved by correct setting up or adjustment of the machines. A good Authorised Dealer should be able to resolve the majority of these issues much more quickly than processing a claim under the guarantee.
- 2.2 Any damage to the Product resulting in a potential claim under the guarantee must be reported to the Authorised Dealer from which it was purchased within 48 hours of receipt.
- 2.3 If the Authorised Dealer who supplied the Product to you has been unable to satisfy your query, any claim made under this Guarantee should be made directly to Record Power or its Authorised Distributor (for details of the Authorised Distributor in your country please see your Product manual or check www.recordpower.info for details). The claim itself should be made in a letter setting out the date and place of purchase, and giving a brief explanation of the problem which has led to the claim. This letter should then be sent with proof of the purchase date (preferably a receipt) to Record Power or its Authorised Distributor. If you include a phone number or email address this will help to speed up your claim.
- 2.4 Please note that it is essential that the letter of claim reaches Record Power or its Authorised Distributor on the last day of this Guarantee at the latest. Late claims will not be considered.

3 Limitation of Liability

- 3.1 We only supply Products for domestic and private use. You agree not to use the Product for any commercial, business or re-sale purposes and we

2. Record Power Guarantee

have no liability to you for any loss of profit, loss of business, business interruption or loss of business opportunity.

3.2 This Guarantee does not confer any rights other than those expressly set out above and does not cover any claims for consequential loss or damage. This Guarantee is offered as an extra benefit and does not affect your statutory rights as a consumer.

4 Notice

This Guarantee applies to all Products purchased from an Authorised Dealer of Record Power within the United Kingdom of Great Britain and Northern Ireland. Terms of Guarantee may vary in other countries – please check with the Authorised Distributor in your country (details of the Authorised Distributor for your country can be found in the manual or at www.recordpower.info).

3. General Health & Safety Guidance

Ensure that you carefully read and fully understand the instructions in this manual before assembly, installation and use of this product. Keep these instructions in a safe place for future reference.

WARNING: for your own safety, do not attempt to operate this machine until it is completely assembled and installed according to these instructions.

WARNING: When using any machine, basic safety precautions should always be followed to reduce the risk of fire, electric shock and personal injury.

Safe Operation

1. Use Personal Protective Equipment (PPE)

- The operation of any machine can result in foreign objects being thrown into your eyes, which can result in severe eye damage. Protective eye wear or other suitable eye protection or face shield should be used at all times. Everyday spectacles only have impact resistant lenses. They are not protective eye wear and do not give additional lateral protection.
- Use respiratory protective equipment (dust mask etc.) if the machining operation creates dust. Exposure to high levels of dust created by machining hardwoods, softwoods and man made composite boards can result in serious health problems. Some imported hardwoods give off highly irritating dust, which can cause a burning sensation. The use of respiratory protective equipment should not be seen as an alternative to controlling the risk of exposure at source by using adequate dust extraction equipment.
- The use of ear plugs or ear defenders is recommended when the machine is in use, particularly if the noise level exceeds 85 dB.
- Wear suitable protective gloves when handling cutting tools or blades. Gloves should NOT be worn when using the machine as they can be caught in moving parts of the machine.
- Non-slip safety footwear is recommended when using the machine and handling large work pieces.

2. Dress appropriately

- Do not wear loose clothing, neckties or jewellery; they can be caught in moving parts of the machine.
- Roll up long sleeves above the elbow.
- Wear protective hair covering to contain long hair.

3. Safety warnings

- Find and read any warning labels on the machine.
- It is important that any labels bearing health and safety warnings are not removed, defaced or covered. Replacement labels can be obtained by contacting our

Customer Service Department.

4. Familiarise yourself with the machine

- If you are not thoroughly familiar with the operation of this machine, obtain advice from your supervisor, instructor, or other qualified person or contact your retailer for information on training courses. Do not use this machine until adequate training has been undertaken.

5. Take care when moving or positioning the machine

- Some machines can be very heavy. Ensure the floor of the area in which the machine is to be used is capable of supporting the machine.
- The machine and its various components can be heavy. Always adopt a safe lifting technique and seek assistance when lifting heavy components. In some cases it may be necessary to use mechanical handling equipment to position the machine within the work area.
- Some machines have optional wheel kits available to allow them to be manoeuvred around the workshop as required. Care should be taken to install these according to the instructions provided.
- Due to the nature of the design of some machines the centre of gravity will be high making them unstable when moved. Extreme care should be taken when moving any machine.
- If transportation of the machine is required then all precautions relating to the installation and handling of the machine apply. In addition, ensure that any vehicles or manual handling equipment used for transportation are of adequate specification.

6. The machine should be level and stable at all times

- When using a leg stand or cabinet base that is designed to be fitted to the machine, always ensure that it is securely fastened to the machine using the fixings provided.
- If the machine is suitable to be used on a workbench, ensure that the workbench is well constructed and capable of withstanding the weight of the machine. The machine should always be securely fastened to the workbench with appropriate fixings.
- Where possible, floor standing machines should always be secured to the floor with fixings appropriate to the structure of the floor.
- The floor surface should be sound and level. All of the feet of the machine should make contact with the floor surface. If they do not, either re-locate the machine to a more suitable position or use packing shims between

3. General Health & Safety Guidance

the feet and the floor surface to ensure the machine is stable.

7. Remove adjusting keys and wrenches

- Ensure that all adjusting wrenches and keys are removed before switching the machine 'ON'. There is a risk of severe personal injury or damage to the machine from airborne objects.

8. Before switching the machine 'ON'

- Clear the machine table of all objects (tools, scrap pieces etc.)
- Make sure there is no debris between the work piece and the table / work support.
- Ensure that the work piece is not pressed against, or touching the saw blade or cutting tool.
- Check all clamps, work holding devices and fences to ensure that they are secure and cannot move during machining operations.
- Plan the way that you will hold and feed the work piece for the entire machining operation.

9. Whilst machining

- Before starting work, watch the machine while it runs. If it makes an unfamiliar noise or vibrates excessively, switch the machine 'OFF' immediately and disconnect it from the power supply. Do not restart until finding and correcting the source of the problem.

10. Keep the work area clear

- Working clearances can be thought of as the distances between machines and obstacles that allow safe operation of every machine without limitation. Consider existing and anticipated machine needs, size of material to be processed through each machine and space for auxiliary stands and/or work tables. Also consider the relative position of each machine to one another for efficient material handling. Be sure to allow yourself sufficient room to safely operate your machines in any foreseeable operation.
- Cluttered work areas and benches create the risk of accidents. Keep benches clear and tidy away tools that are not in use.
- Ensure that the floor area is kept clean and clear of any dust and debris that may create trip or slip hazards.

11. Consider the work area environment

- Do not expose the machine to rain or damp conditions.
- Keep the work area well lit and ensure that there is artificial lighting available when there is insufficient natural light to effectively light the work area. Lighting should be bright enough to eliminate shadow and prevent eye strain.
- Do not use the machine in explosive environments e.g.

in the presence of flammable liquids, gases or dust.

- The presence of high levels of dust created by machining wood can present a risk of fire or explosion. Always use dust extraction equipment to minimise the risk.

12. Keep other persons away (and pets)

- The machine is designed to be used by one person only.
- Do not let persons, especially children, touch the machine or extension cable (if used) and keep visitors away from the work area.
- Never leave the machine running unattended. Turn the power supply off and do not leave the machine unattended until it comes to a complete stop.
- If the work area is to be left unattended, all machinery should be switched 'OFF' and isolated from the mains power supply.

13. Store machines safely when not in use

- When not in use, machines should be stored in a dry place, out of reach of children. Do not allow persons unfamiliar with these instructions or with the machine to operate it.

14. Do not overreach

- Choose a working position that allows your body to remain balanced and feed the work piece in to the machine without overreaching.
- Keep proper footing and balance at all times.

15. Electrical supply

- Electrical circuits should be dedicated to each machine or large enough to handle combined motor amp loads. Power outlets should be located near each machine so that power or extension cables are not obstructing high-traffic areas. Observe local electrical guidelines for proper installation of new lighting, power outlets, or circuits.
- The machine must be connected to an earthed power supply.
- The power supply must be equipped with a circuit breaker that provides short circuit, overload and earth leakage protection.
- The voltage of the machine must correspond to the voltage of the mains power supply.
- The mains plug fitted to the machine should always match the power outlet. Do not modify the plug in any way. If a replacement plug is required it should be fitted by a competent person and of the correct type and rating for the machine.
- If you are unsure about any electrical connections always consult a qualified electrician.

3. General Health & Safety Guidance

16. Avoid unintentional starting of the machine

- Most machines are fitted with a no-volt release (NVR) switch to prevent unintentional starting. If in doubt always ensure the machine switch is in the 'OFF' position before connecting it to the power supply. This means the machine will not automatically start up after a power cut or switching on of the power supply, unless you first reset the start switch.

17. Outdoor use

- Your machine should not be used outdoors.

18. Extension cables

- Whenever possible, the use of extension cables is not recommended. If the use of an extension cable is unavoidable, then it should have a minimum core cross section of 2.5mm² and limited to a maximum length of 3 metres.
- Extension cables should be routed away from the direct working area to prevent a trip hazard.

19. Guard against electric shock

- Avoid body contact with earthed or grounded surfaces such as pipes and radiators. There is an increased risk of electric shock if your body is earthed or grounded.

20. Always work within the machine's intended capacities

- Operator safety and machine performance are seriously adversely affected if attempts to make the machine perform beyond its limits are made.

21. Do not abuse the power cable

- Never pull the power cable to disconnect it from the power socket. Always use the plug.
- Keep the power cable away from heat, oil and sharp edges.
- Do not use the power cable for carrying or moving the machine.

22. Secure the work piece

- Ensure that the work piece is securely held before starting to machine it.
- When working within 300 mm of the machining area, always use a push stick to feed the work piece in to the blade or cutting tool. The push stick should have a minimum length of 400 mm. If the push stick becomes damaged, replace it immediately.
- Use extra supports (roller support stands etc.) for any work pieces large enough to tip when not held down to the table top.
- Do not use another person as a substitute for a table extension, or as additional support for a work piece that is longer or wider than the basic table, or to help feed, support, or pull the work piece.

- Do not attempt to machine more than one work piece at a time.
- When feeding the work piece towards the blade or cutting tool never position your hands in direct line of the cutting path. Avoid awkward operations and hand positions where a sudden slip could cause your hand or fingers to move into the machining area.

23. Stay alert

- Safety is a combination of operator common sense and alertness at all times when the machine is being used.
- Use all machines with extreme care and do not use the machine when you are tired or under the influence of drugs, alcohol or medication.

24. Use the correct tool for the job

- Do not use the machine for any purpose other than which it was designed.
- When selecting replacement cutting tools and blades, always ensure that they are designed to cut the material that you intend to use them for. If in any doubt seek further advice from the manufacturer.

25. Connect dust extraction equipment

- Always use dust extraction equipment. The dust extractor should be of suitable size and capacity for the machine that it is connected to and have a filtration level appropriate to the type of waste being collected. Refer to the relevant section of the manual for details of the specific dust extraction requirements for this machine.
- The dust extractor should be switched 'ON' before starting the machine that it is connected to. The dust extractor should be left running for 30 seconds after the last machining operation is complete in order to clear any residual waste from the machine.

26. Ensure that the machine is correctly guarded

- Never use the machine if any of the standard safety guards and equipment are removed or damaged.
- Some machines incorporate safety interlocks to prevent the machine from being used without the guards in place. Never attempt to bypass or modify the interlocks to allow the machine to be used without the guards in place.

27. Maintain your machine with care

- This manual gives clear instructions on installation, set up and operation of the machine and also details any routine and preventative maintenance that should be performed periodically by the user.
- Remember always to switch off and unplug the machine from the power supply before carrying out any setting up or maintenance operations.
- Follow any instructions for the maintenance of

3. General Health & Safety Guidance

accessories and consumables.

- Do not use compressed air to clean the machine. Always use a brush to dislodge dust in places that are awkward to reach and a dust extractor to collect the waste.
- Inspect electric cables periodically and, if damaged, have them replaced by an authorised service facility or qualified electrician.
- Inspect extension cables (if used) periodically and replace if damaged.

28. Keep cutting tools sharp and clean

- Correctly maintained cutting tools are easier to control and less likely to bind.
- Cutting tools and blades can become hot during use. Take extreme care when handling them and always allow them to cool before changing, adjusting or sharpening them.

29. Disconnect the machine from the power supply

- When not in use, before servicing, changing blades etc. always disconnect the machine from the power supply.

30. Check for damaged parts

- Before each use of the machine, it should be carefully checked to determine that it will operate properly and perform its intended function.
- Check for alignment of moving parts, binding of moving parts, breakage of parts and any other conditions that may affect the operation of the machine.
- A guard or other part that is damaged should be properly repaired or replaced by a qualified person unless otherwise indicated in this instruction manual.
- Do not use the machine if the switch does not turn the machine 'ON' and 'OFF'.

- Have defective switches replaced by a qualified person.

31. Warning!

- The use of any accessory or attachment, other than those recommended in this instruction manual, or recommended by our Company may present a risk of personal injury or damage to the machine and invalidation of the warranty.

32. Have your machine repaired by a qualified person

- This machine complies with the relevant safety rules and standards appropriate to its type when used in accordance with these instructions and with all of the standard safety guards and equipment in place. Only qualified persons using original spare parts should carry out repairs. Failure to do this may result in considerable danger to the user and invalidation of warranty.

33. Caution! Motor may become hot during use

- It is normal for motors on some machines to become hot to the touch during use. Avoid touching the motor directly when in use.

4. Additional Health & Safety Guidance for Bandsaws

Safe Operation

1. Familiarise yourself with the machine

- Machining operations using bandsaws have a history of serious accidents. Most result from contact with the moving blade while presenting material to the blade or moving it from the table. Other minor accidents can occur whilst setting, cleaning, adjusting or maintaining the machine.
- The machine is designed for cutting wood and composite board (plywood, MDF etc.). Certain plastics can also be cut using a suitable blade.

2. Before switching the machine 'ON'

- Ensure that the blade is correctly tensioned and aligned on the band wheels and the blade guides are correctly adjusted.
- Ensure that the teeth of the blade are pointing downwards.
- Check the condition of the blade to ensure that no teeth are missing, damaged or deformed and the blade is not cracked or split. If any of these conditions apply, replace the blade immediately.
- Ensure that the saw blade type and width are suitable for the material to be cut.
- Check that the blade width is within the minimum and maximum permitted on the machine and that the thickness of the blade is suitable for the diameter of the wheel.
- Some machines have more than one cutting speed. For most wood cutting applications the faster of the speeds should be used.
- Check the condition of the table insert. Replace it immediately if it is damaged or showing signs of wear.
- Adjust the guard as close as possible to the work piece being cut.

- Check that access doors are fully closed and that the latches are secure.

3. Whilst machining

- Never apply sideways pressure to the blade as this may cause the blade to break.
- Care must be taken when cutting wood with knots, nails or cracks in it and / or dirt on it, as these can cause the blade to get stuck. If this happens, switch the machine 'OFF' immediately and follow the procedure detailed in the manual to remove the blade from the work piece.
- If cutting cylindrical timber use a suitable jig to prevent twisting of the work piece.

4. This machine falls under the scope of the 'Health and Safety at Work etc. Act 1974', and the 'Provision & Use of Work Equipment Regulations 1998'. In addition the elimination or control of risks from wood dust is included in the above regulations and the 'Control of Substances Hazardous to Health (COSHH) Regulations 2002'. We recommend that you study and follow these regulations.

Further guidance can be found in the 'Safety in the use of narrow bandsaws – Woodworking sheet No.31' and the 'Safe use of woodworking machinery' code of practice booklet (L114) published by Health and Safety Executive and available from their website www.hse.gov.uk.

5. Specifications

Guide bearing groove thickness: 0.67 mm

Weight: 1.24 kg

Maximum depth of cut (BS300E): 135 mm

Maximum depth of cut (BS350S): 175 mm

Scroll blade thickness compatibility: 0.44 mm - 0.65 mm

6. Contents of the Package

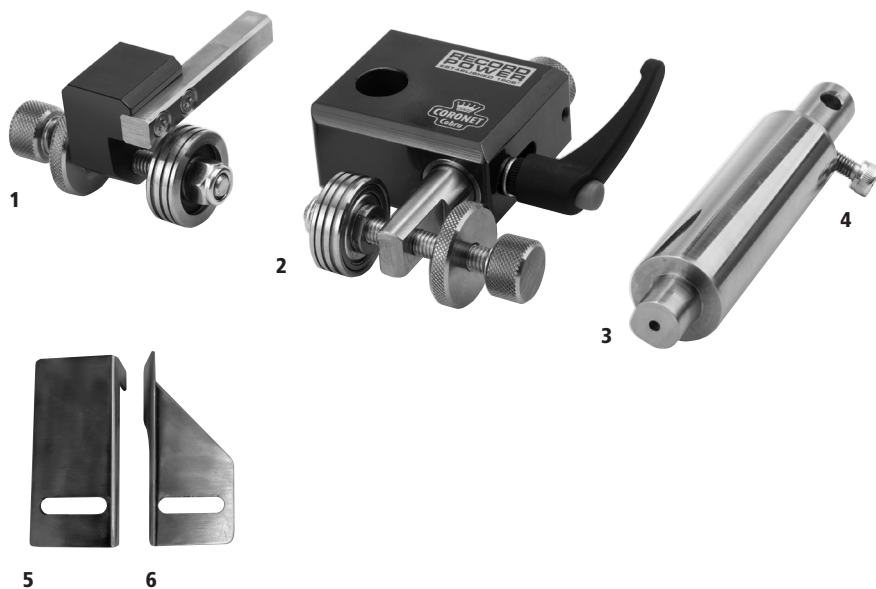

- 1 Lower scroll guide assembly
- 2 Upper scroll guide assembly
- 3 Tool post shaft
- 4 M6 socket head cap screw
- 5 Lower safety guard A
- 6 Lower safety guard B

7. Assembly



Before carrying out the assembly process, ensure that the machine is isolated and disconnected from the electricity supply.



Removing the Bandsaw Blade from the Machine

Remove the bandsaw blade from the machine by following the instructions in the main machine manual.

Removing the Bandsaw Blade Guides from the BS300E/ BS350S

To remove the upper bandsaw blade guides, loosen the M5 socket head cap screw at the rear of the tool post using a 4 mm hex wrench as shown in **Fig 7.1**.

To remove the lower bandsaw blade guides, loosen the 2 M5 socket head cap screws and washers, at either side of the plastic guarding using a 4 mm hex wrench, and remove the plastic guarding from the lower blade guide support, **Fig 7.2**.

Loosen the 2 M6 socket head cap screws located at the front of the guide support using a 5 mm hex wrench, but do not remove the screws fully, **Fig 7.3**.

Remove the lower guides from the guide support by pulling the guides away from the guide shafts, as shown in **Fig 7.4**.

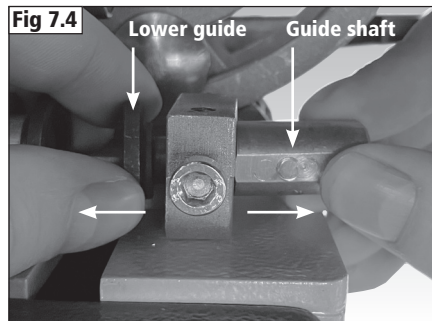
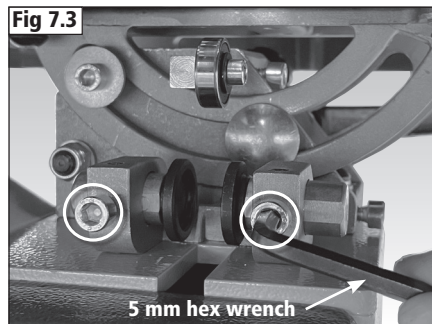
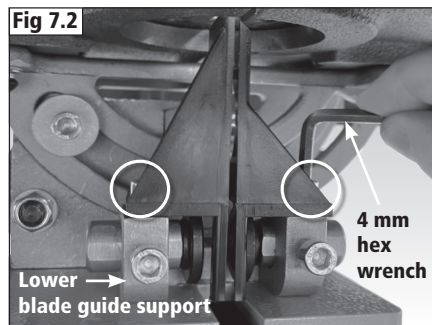
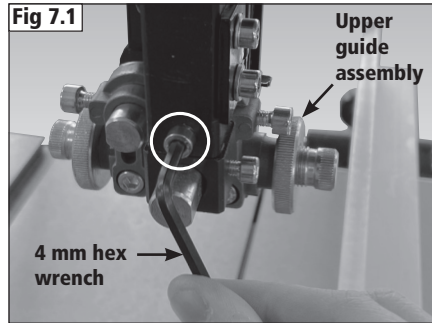

7. Assembly

Remove the guide support from the bandsaw trunnion by loosening the M6 socket head cap screw, as shown in **Fig 7.5**, using a 5 mm hex wrench.



The guide support must be removed to allow sufficient space to fit and adjust the lower scroll guide assembly. Ensure that the guide support is re-fitted to the bandsaw trunnion after the lower scroll guides have been fitted, to accommodate the lower scroll guide safety guard prior to use.

Remove the rear thrust guide (**Fig 7.6**) from the machine by rotating the adjustment knob located at the rear of the machine trunnion anti-clockwise, **Fig 7.7**, and pull the thrust guide shaft away from the machine.



For fitment to machines featuring a hole for connectivity on the bandsaw tool post (as shown in the image below), follow method A on this page until Fig 7.14. After Fig 7.14, proceed in fitting the lower guide assembly.

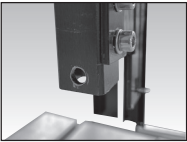

A

For fitment to machines featuring a threaded hole for connectivity on the bandsaw tool post (as shown in the image below), follow method B on page 16 from Fig 7.15.

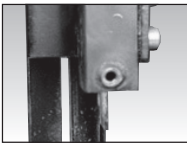

B

To fit the tool post shaft to the upper scroll guide block, loosen the M6 set screw from the upper scroll guide assembly, using a 3 mm hex wrench, but do not remove fully, **Fig 7.8**.

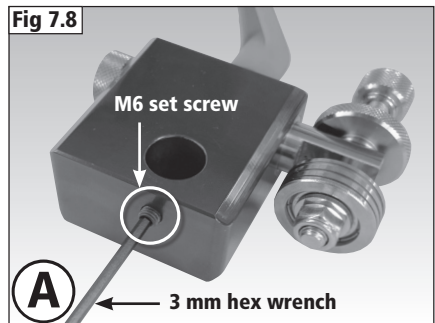
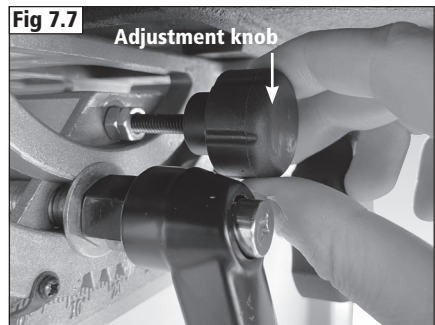
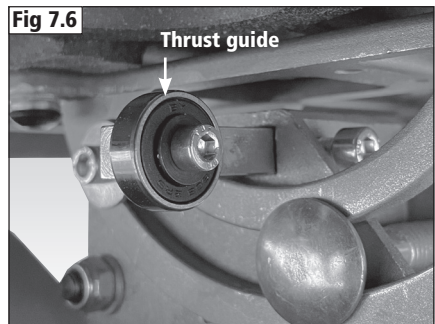
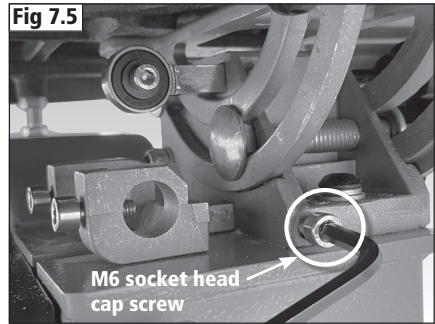

7. Assembly

Insert the lower end of the tool post shaft into the 16 mm hole within the upper scroll guide block, ensuring that the threaded hole, located at the top of the shaft (**Fig 7.9**), is facing towards the rear of the guide assembly, whilst also ensuring that the machined flat surface located at the lower end of the shaft is facing towards the M6 set screw, **Fig 7.10**.

Secure the tool post in place by tightening the M6 set screw, **Fig 7.11**.

Fitting the Upper Scroll Guide Assembly to the Machine Tool Post

Loosen the lower of the 2 M5 socket head cap screws located on the side of the machine tool post, using a 4 mm hex wrench, but do not fully remove, **Fig 7.12**.

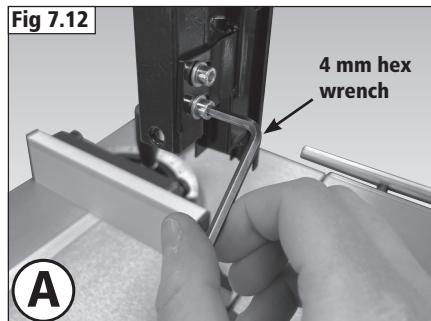
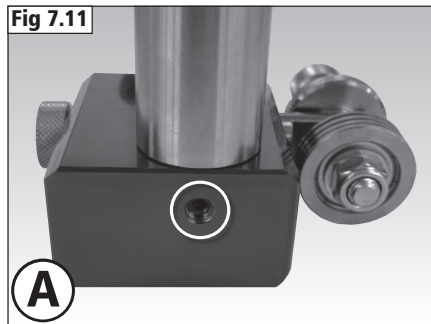
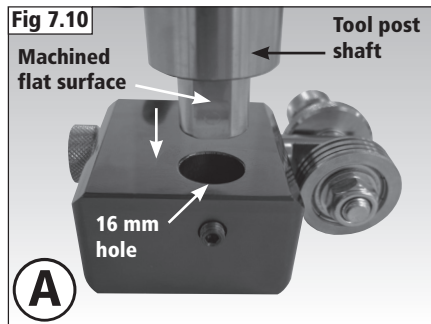
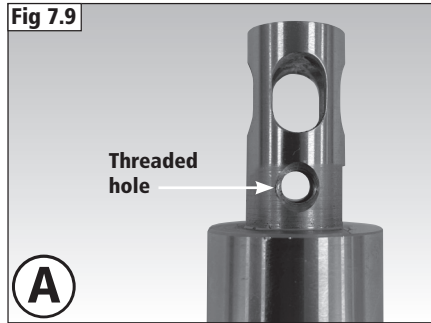

7. Assembly

Insert the top end of the tool post shaft (featuring the threaded hole) into the bandsaw tool post, ensuring that the threaded hole is facing the rear of the machine and that the upper thrust guide bearing is facing the machine front, **Fig 7.13**.

To secure the tool post shaft into position, fully tighten the lower M5 socket head cap screw on the machine tool post, then at the rear, thread the supplied M6 socket head cap screw through the hole within the machine tool post, **Fig 7.13**, and into the threaded hole within the tool post shaft and fully tighten, using a 5 mm hex wrench, **Fig 7.14**.



For fitment to machines featuring a threaded hole for connectivity on the bandsaw tool post (as shown in the image below), follow method B on this page from Fig 7.15.

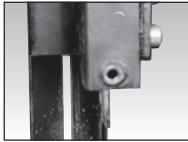

B

Loosen the M6 set screw from the upper scroll guide block, using a 3 mm hex wrench, but do not remove fully, **Fig 7.15**.

Insert the lower end of the tool post shaft into the 16 mm hole within the upper scroll guide block, ensuring that the machined flat surface (**Fig 7.16**) located at the top of the tool post shaft is facing towards the rear of the guide block, and that the machined flat surface located at the

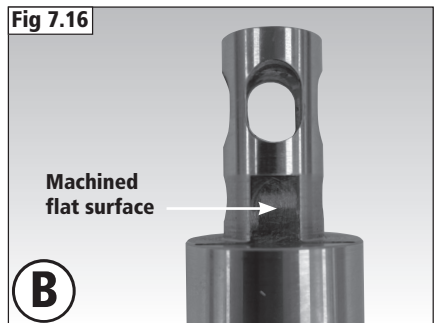
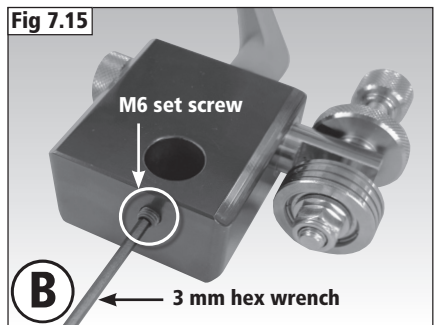
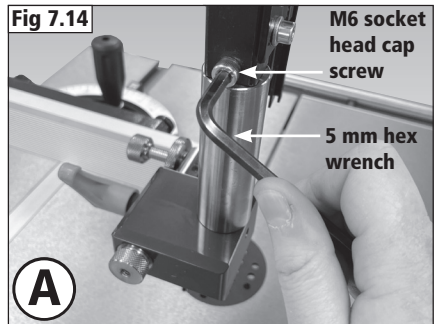
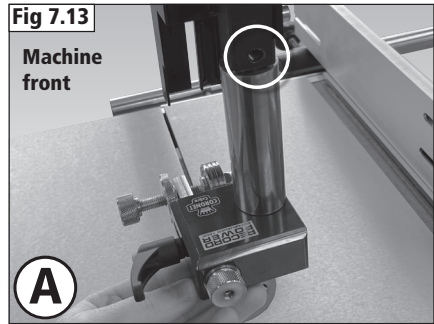

7. Assembly

lower end of the shaft is facing towards the M6 set screw, **Fig 7.17**.

Secure the tool post in place by tightening the M6 set screw, **Fig 7.18**.

Fitting the Upper Scroll Guide Assembly to the Machine Tool Post

Loosen the lower of the 2 M5 socket head cap screws located on the side of the machine tool post, using a 4 mm hex wrench, but do not fully remove, **Fig 7.19**.

Insert the top end of the tool post shaft (featuring the machined flat surface) into the bandsaw tool post, ensuring that the thrust guide bearing is facing the machine front, **Fig 7.20**.



Note: When fitting the tool post shaft into tool posts featuring a threaded hole for connectivity, use the M5 socket head cap screw supplied with the original upper bandsaw blade guide assembly and do not use the M6 socket head cap screw, supplied with the **80003 Coronet Cobra** Bandsaw Scroll Guide System package.

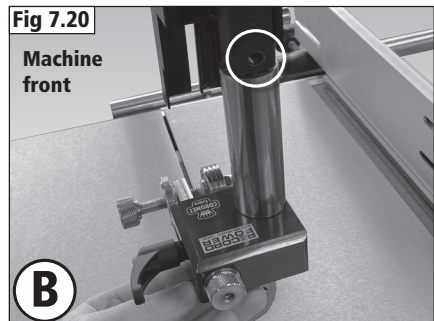
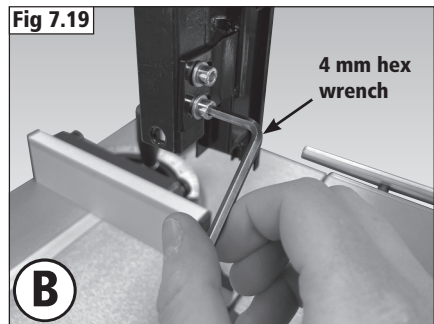
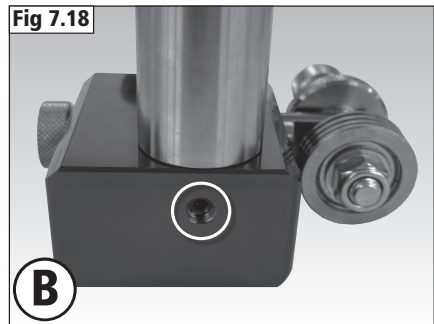
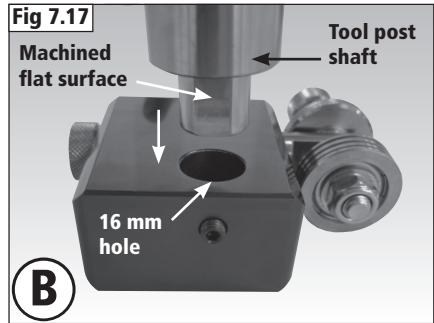

7. Assembly

To secure the tool post shaft into position, fully tighten the lower M5 socket head cap screw on the machine tool post, then at the rear, thread the M5 socket head cap screw, previously removed from the standard bandsaw blade guides, through the threaded hole within the machine tool post and onto the machined flat surface on the tool post shaft and fully tighten, using a 4 mm hex wrench, **Fig 7.21**.

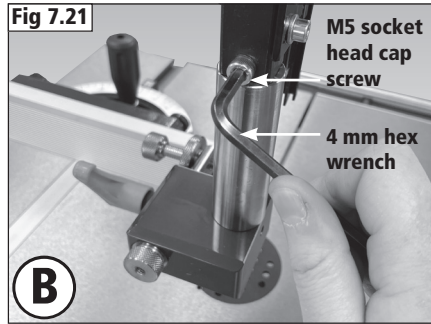

Fitting the Lower Scroll Guide Assembly to the Bandsaw Trunnion

Insert the lower guide thrust housing shaft into the location on the machine trunnion and secure in place by rotating the adjustment knob clockwise at the rear, as shown in **Fig 7.22** and **Fig 7.23**.



Ensure that the guide support is re-fitted to the bandsaw trunnion to accommodate the lower scroll guide safety guard.

The lower scroll guide safety guard consists of 2 separate parts, A and B, which work together to conceal the scroll blade and protect the user.

Fitting the Lower Scroll Guide Safety Guard

Position **guard A** to the left-hand side of the lower bandsaw blade guide support, ensuring that it is positioned as shown in **Fig 7.24**.

Secure in place by threading an M6 socket head cap screw (supplied with the lower bandsaw blade guides) through the threaded hole, using a 5 mm hex wrench, **Fig 7.24**.

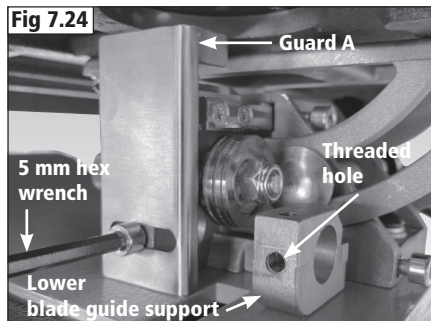
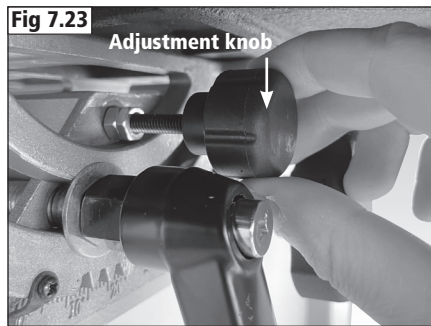
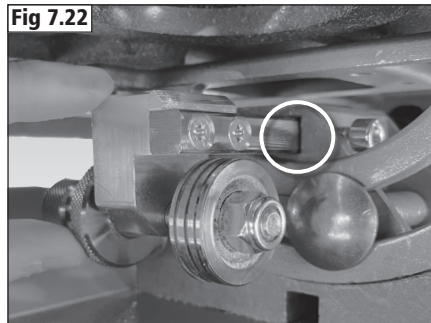

7. Assembly

Position **guard B** to the right-hand side of the lower blade guide support as shown in **Fig 7.25**, and secure in position in the same way.



Fitting the Scroll Blade to the Machine

Before fitting the scroll blade ensure that the machine is fully de-tensioned.

Fit the scroll blade around the top and bottom band wheels, **Fig 7.26**.



Before tracking, apply tension to the blade (but not in full) so that it does not move from the centre of the band wheel when tracking.

The blade must be tracked into 1 of the 3 location grooves featured on the upper and lower thrust guides.

Adjusting the Upper Thrust Guide Bearing to Bring it Towards the Scroll Blade

Loosen the locking handle on the side of the upper guide block, **Fig 7.27**, and rotate the thrust guide adjustment knob, **Fig 7.28**, clockwise.

Rotate the thrust guide adjustment knob anti-clockwise to retract.



The upper thrust guide should be positioned approximately 6 mm/ 1/4" from the rear of the scroll blade, to allow support for blade tracking.

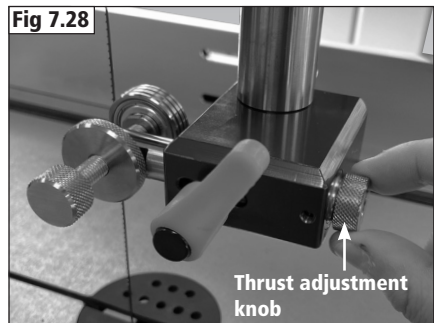
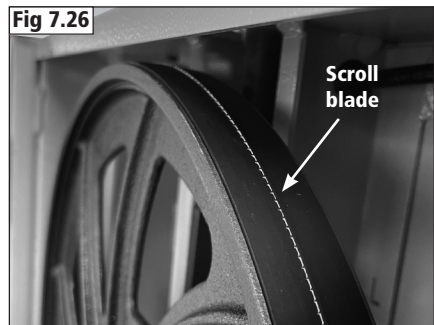
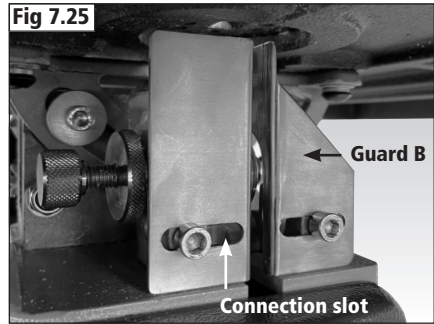

7. Assembly

Adjusting the Upper Thrust Guide Bearing Left and Right

Loosen the thrust guide adjustment lock, as shown in **Fig 7.29**, and rotate the thrust guide side adjustment knob clockwise or anticlockwise to correctly align with the scroll blade, **Fig 7.30**.



Note: Lower scroll guide safety guard and lower guide support removed for viewing purposes.

Adjusting the Lower Thrust Guide Bearing to Bring it Towards the Scroll Blade

Rotate the adjustment knob at the rear of the machine trunnion, **Fig 7.31**, clockwise to bring the lower thrust guide bearing towards the scroll blade, **Fig 7.32**.

Rotate the adjustment knob anti-clockwise to retract.



The lower thrust guide should be positioned approximately 6 mm/ 1/4" from the rear of the scroll blade, to allow support for tracking.

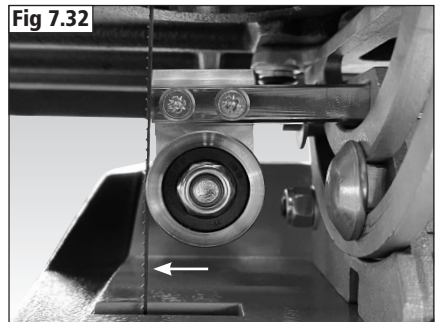
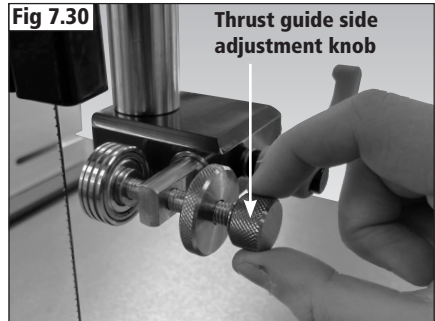
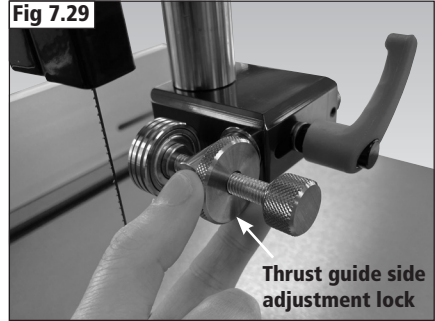

7. Assembly

Location Grooves on the Upper and Lower Thrust Guide Bearings

Once the blade has been correctly tracked and fully tensioned, the upper and lower thrust guides can be adjusted so that the blade can sit inside 1 of the 3 location grooves on the upper and lower thrust guide bearings, as shown in **Fig 7.37** and **Fig 7.38**.

Once the blade is positioned correctly, lock the thrust guide bearings in place.



Before use it is essential to ensure the blade guards are installed.

See pages 18 and 19 for lower scroll guide safety guard fitment instructions.

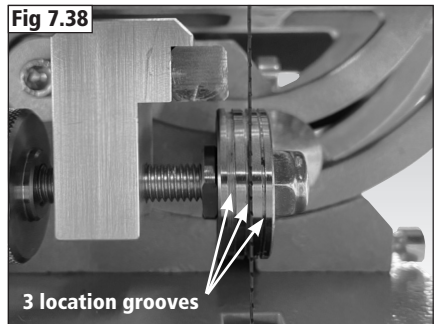
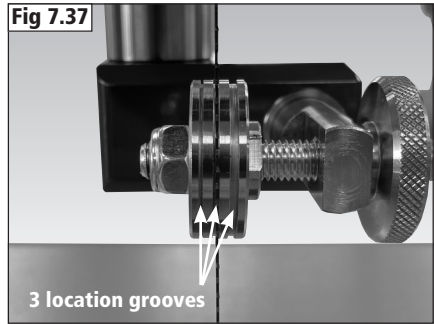

8. Operation

Basic Bandsawing Principles

- The blade cuts on a continuous down stroke.
- Slowly feed the workpiece towards the blade, using only light pressure whilst letting the blade do the cutting.
- Firmly hold the workpiece and feed it towards the blade slowly, keeping your hands well away from the blade.
- For best results the blade must be sharp. Damaged or worn blades should always be replaced.
- To achieve a consistent finish to the workpiece, feed it through the blade at a consistent speed.



CAUTION! Particular care should be taken towards the end of the cut as there will be a sudden decrease in resistance and care must be taken to stop hands from being thrown towards the blade.

Always ensure that your machine is properly maintained and clean. Before commencing work on an important project, it is advisable to familiarise yourself with the operation of the equipment by practising on low value or scrap materials.



WARNING! In the event that the blade stalls whilst cutting, ease the work piece backwards slightly, to release feed pressure from the blade. Allow the blade to reach full speed before continuing to feed the work piece in to the blade. If the blade fails to move when feed pressure is released, immediately switch off the machine and disconnect the power supply before attempting to free the blade from the work piece.



WARNING! If any component of the machine fails whilst in use or if the blade should break whilst the machine is running, immediately switch off the machine and disconnect from the power supply. Remove the faulty component and replace only with genuine Record Power replacement parts. Any electrical components should only be replaced by a suitably qualified person. Always remember to fully release the blade tension mechanism before attempting to fit a new blade. If you are in any doubt about using the machine following a failure or if you need to order replacement spare parts or blades, please contact customer services in your country.

Restarting In the Event of a Blockage or if the Machine Stalls

If the bandsaw stalls due to the blade becoming trapped in the work piece, switch it off immediately by pressing the emergency stop button and wait for the machine to come to a complete stop before proceeding further.

If the blade is trapped within the work piece, it may be necessary to prise the work piece apart slightly using a suitable lever in order to free the blade.

8. Operation

If it is not possible to free the blade using this method, then it may be necessary to cut the blade using suitable side cutters or tin snips.

Replace the blade if necessary and ensure that it is correctly tracked and tensioned and that both doors of the bandsaw are fully closed and secured before attempting to restart the machine.

Blade Selection (TPI)

The selection of the best blade configuration is necessary for optimum cutting performance.

- Correct blade choice is primarily dependant on two factors: material thickness and material type.
- Greater TPI should be selected as material thickness decreases.
- However, if the TPI is too great, the tooth loading will be insufficient to enable penetration; and cutting. The teeth will also rapidly lose their sharpness.
- For thicker material a lower TPI should be used otherwise the gullet will not be sufficient to clear the waste and the blade will stall or burn the wood.
- In general a minimum of 3 teeth should be in contact with the wood at all times during cutting.

9. Maintenance

Cleaning the Thrust Guide Bearings

Ensure that the 3 thrust guide bearing location grooves are kept free from wood dust.

Cleaning the Machine Table

Ensure that the machine table is kept clean and free of debris.



Using Effective Dust Extraction

The use of respiratory protective equipment is recommended to help protect against harmful wood dust.

See **chapter 10** for further dust extraction information.



Spare Parts

If you need to order replacement spare parts or blades, please contact customer services in your country.

10. Dust Extraction

The Importance of Dust Extraction

Suitable dust extraction is essential to avoid the possibility of serious health problems related to wood dust. It is also necessary in order to ensure the waste producing machine performs safely and effectively. Some woods are extremely toxic and in addition to suitable dust extraction machines it is recommended that PPE such as respirators are also used.

Record Power Dust Extraction Machines

Below is a summary of the Record Power range. Please visit your local stockist or go online for full details.

DX1000 Fine Filter 45 Litre Extractor

45 litre capacity, 1 kW motor, 0.5 micron filtration.

CGV286 CamVac Series Compact Extractor

36 litre capacity, 1 kW single or twin motor, 0.5 micron filtration.

CGV286-3-WALL CamVac Series Wall Mounted Extractor

150 litre capacity, twin motor, 0.5 micron filtration.

CGV336 CamVac Series Medium Extractor

55 litre capacity, 1 kW single or twin motor, 0.5 micron filtration.

CGV386 CamVac Series Large Extractor

90 litre capacity, 1 kW twin or triple motor, 0.5 micron filtration.

CGV486 CamVac Series Heavy Duty Extractor

200 litre capacity, 1 kW triple motor, 0.5 micron filtration.

AC400 2 Stage Air filter with Remote, 3 speeds and Time Delay

Collects airborne dust, 1 micron filtration.

| | Bandsaws | Table Saws | Planer Thicknessers | Lathes | Sanding Machines | Dust Extraction Systems | Airborne Dust Collection |
|---------------|----------|------------|---------------------|--------|------------------|-------------------------|--------------------------|
| DX1000 | ✓ | ✓ | ✓ | ✓ | ✓ | | |
| CGV286 | ✓ | ✓ | ✓ | ✓ | ✓ | | |
| CGV286-3-WALL | ✓ | ✓ | ✓ | ✓ | ✓ | ✓ | |
| CGV336 | ✓ | ✓ | ✓ | ✓ | ✓ | | |
| CGV386 | ✓ | ✓ | ✓ | ✓ | ✓ | ✓ | |
| CGV486 | ✓ | ✓ | ✓ | ✓ | ✓ | ✓ | |
| AC400 | | | | | | | ✓ |

11. Parts Lists & Diagrams

Upper Scroll Guide Assembly

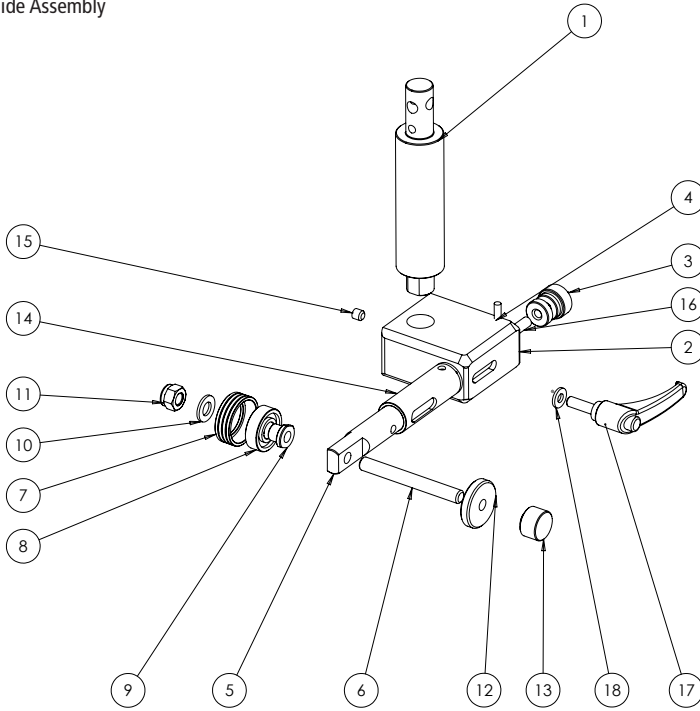

| No. Code | Part Number | Description | Quantity |
|----------|-------------|-----------------------------------|----------|
| 1 | SA0207 | Tool post shaft | 1 |
| 2 | SA0208 | Top guide block | 1 |
| 3 | SA0210 | Thrust adjustment knob | 1 |
| 4 | 99338 | M4 x 12 cheese head | 1 |
| 5 | SA0209 | Thrust guide main shaft | 1 |
| 6 | 99337 | M8 x 70 stud | 1 |
| 7 | SA0214 | Bearing cap | 1 |
| 8 | 99336 | Bearing 6000 ZZ C3 | 1 |
| 9 | SA0214 | Bearing mount | 1 |
| 10 | 99352 | 8 mm washer | 1 |
| 11 | 99291 | 8 mm nyloc nut | 1 |
| 12 | SA0212 | Thrust guide side adjustment lock | 1 |
| 13 | SA0211 | Thrust guide side adjustment knob | 1 |
| 14 | SA0215 | Steel tube | 1 |
| 15 | 99339 | M6 x 6 socket set screw | 1 |
| 16 | 99340 | M6 x 30 socket set screw | 1 |
| 17 | 99341 | Clamping lever | 1 |
| 18 | 99311 | 6 mm washer | 1 |

11. Parts Lists & Diagrams

Lower Scroll Guide Assembly

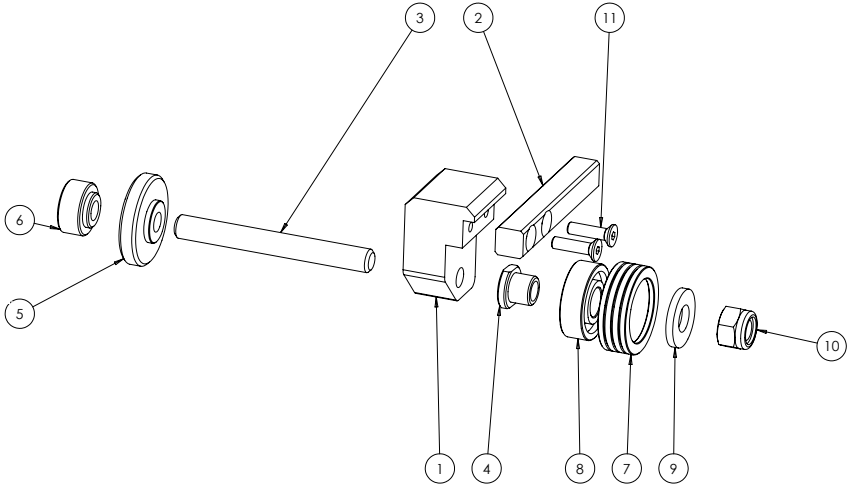

| No. Code | Part Number | Description | Quantity |
|----------|-------------|-----------------------------------|----------|
| 1 | SA0217 | Lower guide thrust housing | 1 |
| 2 | SA0216 | Lower guide thrust housing shaft | 1 |
| 3 | 99337 | M8 x 70 stud | 1 |
| 4 | SA0214 | Bearing mount | 1 |
| 5 | SA0212 | Thrust guide side adjustment lock | 1 |
| 6 | SA0211 | Thrust guide side adjustment knob | 1 |
| 7 | SA0213 | Bearing cap | 1 |
| 8 | 99336 | Bearing 6000 ZZ C3 | 1 |
| 9 | 99352 | 8 mm washer | 1 |
| 10 | 99291 | 8 mm nyloc nut | 1 |
| 11 | 99350 | M4 x 16 counter sunk screw | 2 |



Over
100
 years
 Experience • Knowledge
 Support • Expertise

RECORD POWER
 ESTABLISHED 1909®

Woodworking Machinery and Accessories

Record Power Ltd, Centenary House, 11 Midland Way, Barlborough Links, Chesterfield, Derbyshire S43 4XA
 Tel: +44 (0) 1246 571 020 Fax: +44 (0) 1246 571 030 www.recordpower.co.uk

To register a product and find your local stockist visit

recordpower.info