

## The Robert Sorby Modular Micro tool system

The Modular handled micro Spiral tool is just one of the products from the Robert Sorby Modular micro tool system. It is also available as a Modular micro Spiral tool which comes without a handle.

This quick and simple system allows the woodturner to utilise one handle with an array of tools. Just one of the Modular micro handled sets need to be purchased and then any of the Modular micro sets without handle can be added to it.

By adjusting two locking screws in the handle, the tool can be interchanged from Sandmaster to turning tool and swan neck hollowing to Spiral system.

Other sets available are:

### Modular Micro handled Sandmaster

It utilises a 1" (25mm) sanding pad enabling it to access difficult to get at areas. The sanding pad has a sponge section to allow it to blend into any curve and follow the shape of the project being sanded. The sponge also helps to dissipate any heat that may be built up from friction.

### Modular Micro handled Spindle set.

Comprising of a 1/2" (13mm) gouge, a 1/4" (6mm) skew and a 5/32" (4mm) Beading and parting tool the Spindle set gives the woodturner the tools needed to produce beautiful intricate turned pieces.

### Modular Micro Handled Hollowing set

When used in conjunction with the Spindle set to produce the exterior of small intricately detailed shapes, the Hollowing set can be used to remove all the waste material from inside.

The boring tool will remove a lot of waste material very quickly, this will allow the swan neck tool in to produce fine hollow pieces such as vases. The 1/4" (6mm) round nose scraper will allow the exterior of the piece to be finished.

All of the above sets, Sandmaster, Spiral are available as Modular Micro sets without handles and all the Spindle and Hollowing tools are available without handles.

Available at all Robert Sorby stockists.

For further information contact:

Robert Sorby Ltd, Athol Road, Sheffield, S8 0PA, Telephone: +44 (0) 114 225 0700,  
Email: [sales@robert-sorby.co.uk](mailto:sales@robert-sorby.co.uk), Website: [www.robert-sorby.co.uk](http://www.robert-sorby.co.uk)

Registered in England: Company No 3464018,  
Registered office: Atlas Way, Atlas North, Sheffield, S4 7QQ  
VAT No GB 172 4019 84

*Robert Sorby* Modular Handled Micro Spiral tool

The Modular Handled Micro Spiral tool is the perfect addition to any woodturner's armoury. Like its much bigger brother the Spiralling and Texturing System (330H) this tool uses toothed cutters to produce beautiful spirals and textures on any turned piece.

The advantage of the Micro Spiral tool allows the user to get much closer and produce finer spirals on delicate work.

Because of the fine teeth of the cutters it is recommended that only wood with a very close grain or man-made materials are used to ensure a clean spiral.

Textures and patterns can be produced on any wood grain or other turning material.

The bearing of the Micro Spiral tool is a phosphor-bronze bush which must be kept lubricated with a fine oil to ensure life long free running operation.

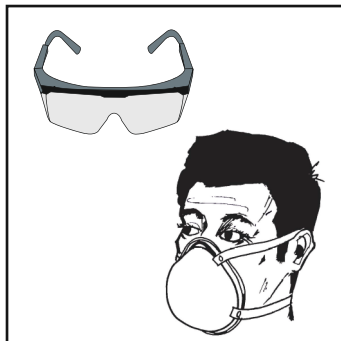

Always use eye protection and a form of dust mask as well as an air cleaner and dust extractor when doing any form of woodworking.

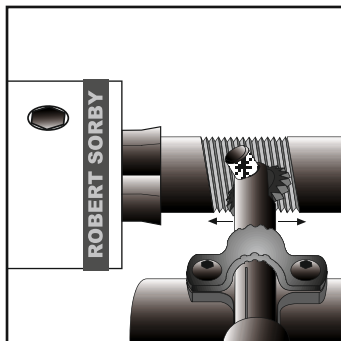

Hold the tool at this angle and slowly move the tool left and right to the length of spiral required. Allowing the cutter to form the shape of the helix on each pass.

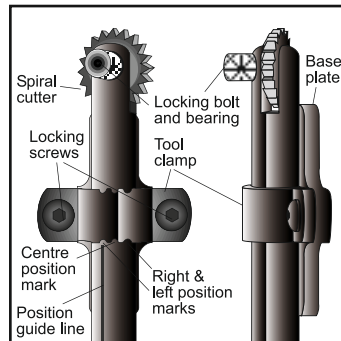

The Spiral tool can be adjusted to cut left and right spirals by loosening the locking screws, turning the shaft so the guideline is in line with any of the left or right position marks and re-tightening the screws.



A huge variety of patterns and textures can also be produced by using the points and edges of the teeth and by changing the speed of the lathe.

**Notice:**  
Set the lathe to 400rpm on a 2" (50mm) diameter piece of wood and slower on larger pieces.

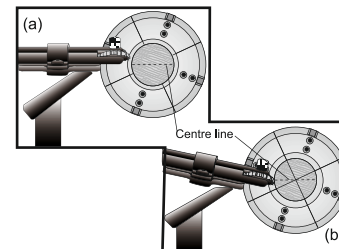

Place the lathe tool rest so the top of the base plate is in line with the centre of the lathe. Allow the cutter to touch the wood and start to rotate (a). With the cutter rotating, start to lift the handle until the tips of the teeth are cutting on centre (b).

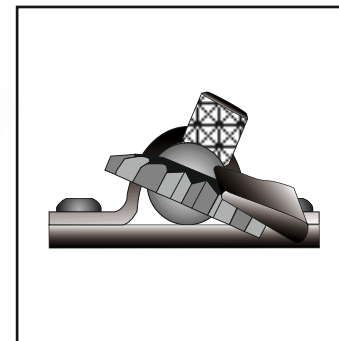

Use a diamond file or honing stone to sharpen the top bevelled face of the cutter. Slowly rotate the cutter while rubbing the stone or file across the bevelled face keeping it at the same angle at all times.